



# Gen2 series

## (C60D, C70D, C80D)

### ● STANDARD SPECIFICATIONS

		CLARK	CLARK	CLARK	
Specifications	1.1 Manufacturer (Abbreviation)		<b>CLARK</b>	<b>CLARK</b>	
	1.2 Manufacturer's designation		<b>C60D</b>	<b>C70D</b>	
	1.3 Drive Unit Diesel, L.P. Gas		Diesel	Diesel	
	1.4 Operator type stand on / driver seated		Driver Seated	Driver Seated	
	1.5 Load Capacity / rated load	Q(kg)	6000	7000	8000
	1.6 Load Center distance	C(mm)	600	600	600
	1.8 Load Center distance, center of drive axle to fork face	x(mm)	617	617	617
	1.9 Wheelbase	y(mm)	2250	2250	2500
	WT	2.1 Service weight	kg	9260	9630
2.2 Axle loading, laden front / rear		kg	13296/1964	14717/1913	15989/2371
2.3 Axle loading, unladen front / rear		kg	4050/5210	3931/5699	4034/6326
Tyres, Chassis	3.1 Tire type, P=pneumatic, SE=super-elastic, C=cushion 1)		P	P	P
	3.2 Tire size, front		8.25×15-14PR	8.25×15-14PR	8.25×15-18PR
	3.3 Tire size, rear		8.25×15-14PR	8.25×15-14PR	8.25×15-18PR
	3.5 Wheels, number front/rear (x=drive wheels)		4X/2	4X/2	4X/2
	3.6 Tread, front	b10(mm)	1575	1575	1575
	3.7 Tread, rear	b11(mm)	1610	1610	1610
	Dimensions	4.1 Tilt of upright/fork carriage, $\alpha / \beta$	Grad	10/15	10/15
4.2 Height, upright lowered		h1(mm)	2480	2480	2480
4.3 Freelift		h2(mm)	222	222	232
4.4 Lift height 2)		h3(mm)	3000	3000	2800
4.5 Height upright extended 6)		h4(mm)	4232	4232	4025
4.7 Height overheadguard (cab): Std / Container		h6(mm)	2370	2370	2370
4.8 Seat height		h7(mm)	1320	1320	1320
4.19 Overall length		l1(mm)	4710	4770	5095
4.20 Length to face of forks		l2(mm)	3510	3570	3895
4.21 Width		b1(mm)	2125	2125	2125
4.22 Fork dimensions		sxexl(mm)	60×150×1200	60×150×1200	70×180×1200
4.23 Fork carriage DIN 15173, A, B			CLVA	CLVA	CLVA
4.24 Fork carriage width		b2(mm)	2125	2125	2125
4.31 Ground clearance minimum		m1(mm)	200	200	200
4.32 Ground clearance center of wheelbase	m2(mm)	230	230	230	
4.34 Right angle stack aisle(Add load length and clearance)	Ast(mm)	5437	5467	5792	
4.35 Outside turning radius	wa(mm)	3420	3450	3775	
Performance	5.1 Travel speed laden/unladen	km/h	29.3/34.4	28.1/33.7	27.4/32.2
	5.2 Lift speed laden/unladen	m/s	0.43/0.45	0.42/0.45	0.39/0.45
	5.3 Lowering speed laden/unladen	m/s	0.45/0.43	0.45/0.43	0.45/0.43
	5.6 Max. drawbar pull laden/unladen 4)	kg	6397/6173	6440/6182	6370/6135
	5.8 Max. gradeability laden/unladen 4)	%	43.8/21.2	41.6/19.8	37.6/19.2
	5.10 Service brake 6)		Wet disc brake	Wet disc brake	Wet disc brake
I.C.-Engine	7.1 Manufacturer/Type		IVECO/N45-MNS	IVECO/N45-MNS	IVECO/N45-MNS
	7.2 Rated output acc. DIN 70020	kw	74	74	74
	7.3 Rated speed acc. DIN 70020	min-1	2300	2300	2300
	7.4 No. of cylinders/displacement	/cm <sup>3</sup>	4/4500	4/4500	4/4500
Miscell.	8.1 Type of control		Hydrodyn	Hydrodyn	Hydrodyn
	8.2 Operating pressure for attachments	Bar	140	140	140
	8.4 Sound level, driver's ear 5)	dB(A)	83	83	83

• Materials and specifications are subject to change without notice.

1) optional with super-elastic types 2) Further lift heights see upright table 3) Laden with 1.6km/h 4) At friction coefficient  $\mu=0.6$

5) Equivalent permanent sound-pressure level  $L_{pAeq, T}$  in accordance with DIN EN 12053(previously DIN 45635-36) 6) Without load backrest

### ● STANDARD DIMENSIONS

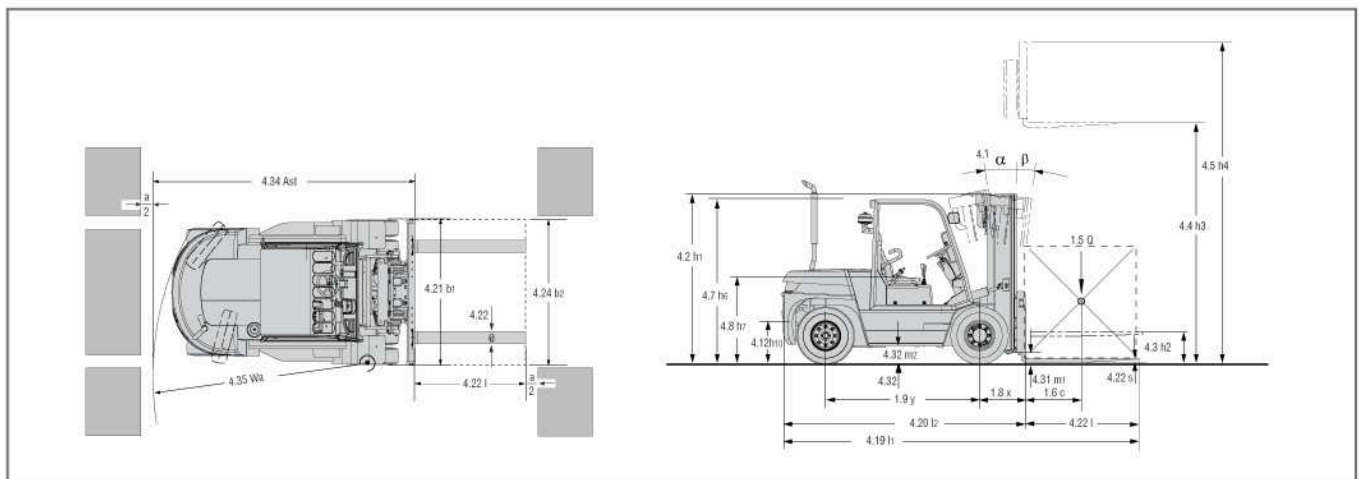

## LOAD CAPACITY CHART

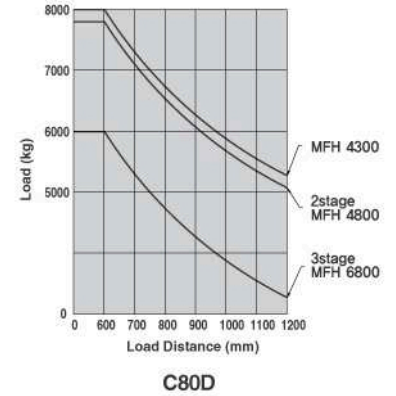
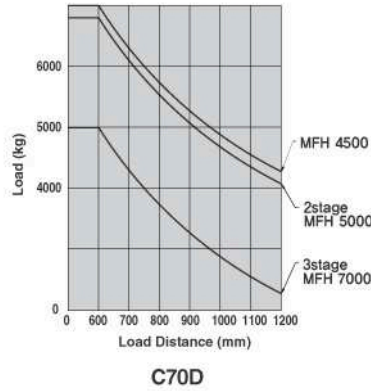
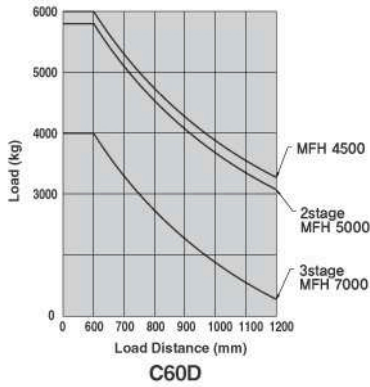

## MAST SPECIFICATIONS & RATED CAPACITIES

Mast type	Maximum fork height	Mast height		Free lift		Tilt angle		Load capacity at 600mm load center	
		lowered	extended	With LBR	Without LBR	FWD	BWD	C60D	C70D
		mm	mm	mm	mm	deg.	deg.	kg	kg
2 stage	2500	2230	3732	223	223	15	10	6000	7000
	2700	2330	3932	223	223	15	10	6000	7000
	3000	2480	4232	223	223	15	10	6000	7000
	3300	2630	4532	223	223	15	10	6000	7000
	3500	2730	4732	223	223	15	10	6000	7000
	3700	2830	4932	223	223	15	10	6000	7000
	4000	2980	5232	223	223	10	10	6000	7000
	4500	3230	5732	223	223	10	10	6000	7000
	5000	3480	6232	223	223	10	10	5800	6800
	5500	3730	6732	223	223	10	10	5300	6300
	6000	3880	7232	223	223	6	6	4900	5900
6400	4180	7632	223	223	6	6	4800	5800	
3 stage	3850	2315	5078	2315	2315	10	10	6000	7000
	4000	2365	5228	2365	2365	10	10	6000	7000
	4500	2533	5732	2533	2533	10	10	6000	7000
	4900	2667	6134	2667	2667	10	10	5800	6800
	6200	3099	7430	3099	3099	6	6	4800	5800
	7000	3365	8238	3365	3365	6	6	4000	5000
	8000	3887	9238	3887	3887	6	6	3000	4000

Mast type	Maximum fork height	Mast height		Free lift		Tilt angle		Load capacity at 600mm load center	
		lowered	extended	With LBR	Without LBR	FWD	BWD	C80D	
		mm	mm	mm	mm	deg.	deg.	kg	
2 stage	2300	2230	3525	223	223	15	10	8000	
	2500	2330	3725	223	223	15	10	8000	
	2800	2480	4025	223	223	15	10	8000	
	3100	2630	4325	223	223	15	10	8000	
	3300	2730	4525	223	223	15	10	8000	
	3500	2830	4725	223	223	15	10	8000	
	3800	2980	5025	223	223	10	10	8000	
	4300	3230	5525	223	223	10	10	8000	
	4800	3480	6025	223	223	10	10	7800	
	5300	3730	6525	223	223	10	10	7300	
	5800	3880	7025	223	223	6	6	6900	
6200	4180	7425	223	223	6	6	6800		
3 stage	3650	2315	4881	2315	2315	10	10	8000	
	3800	2365	5031	2365	2365	10	10	8000	
	4300	2533	5535	2533	2533	10	10	8000	
	4700	2667	5937	2667	2667	10	10	7800	
	6000	3099	7233	3099	3099	6	6	6800	
	6800	3365	8041	3365	3365	6	6	6000	
7800	3887	9041	3887	3887	6	6	5000		

• Materials and specifications are subject to change without notice.